

8 7 6 5 4 3 2 1

D

D

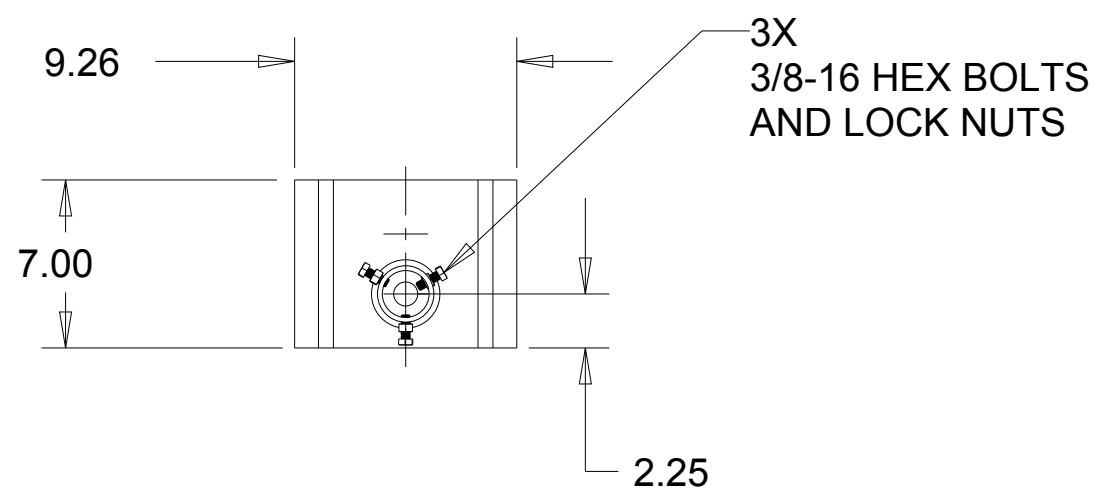

ITEM 2
SEE SHEET 3

ITEM 4
SEE SHEET 5

ITEM 1
SEE SHEET 2

C

C

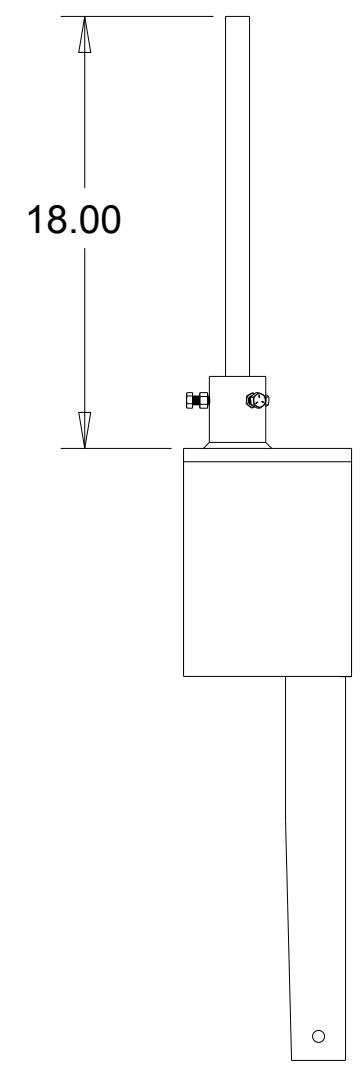
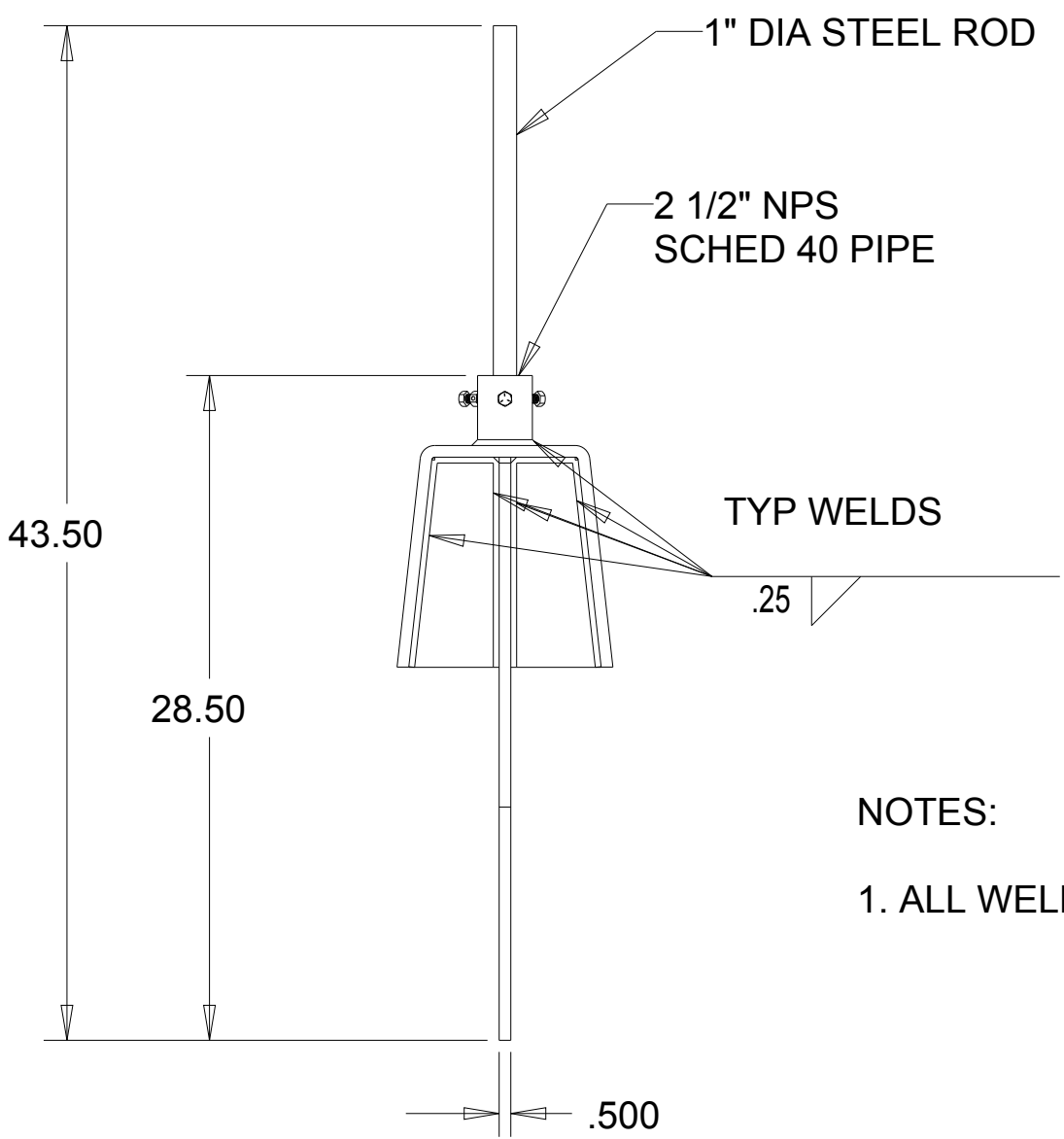

ITEM 3
SEE SHEET 4

B

B

NOTES:

1. ALL WELDS TO BE 1/4"

A

		DRAWN BY: KEVIN RAY	
		DESCRIPTION: EZ-SLIP END BRACKET	
DATE:11/10/17	SHEET 1	REV A2	

8 7 6 5 4 3

8 7 6 5 4 3 2 1

D

D

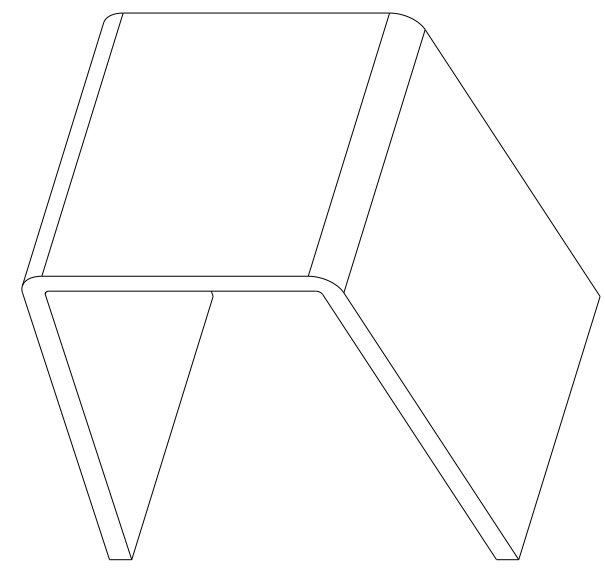
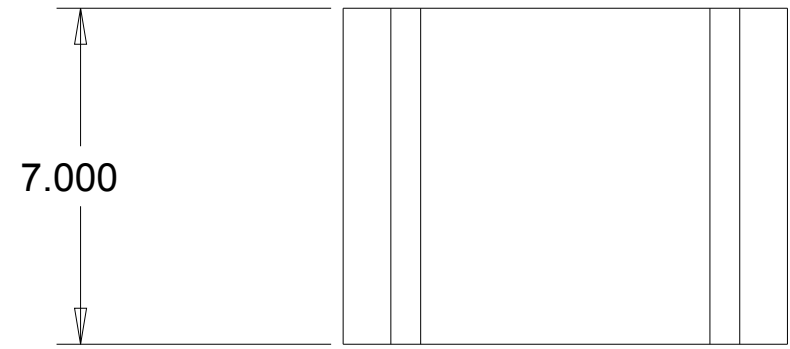

C

C

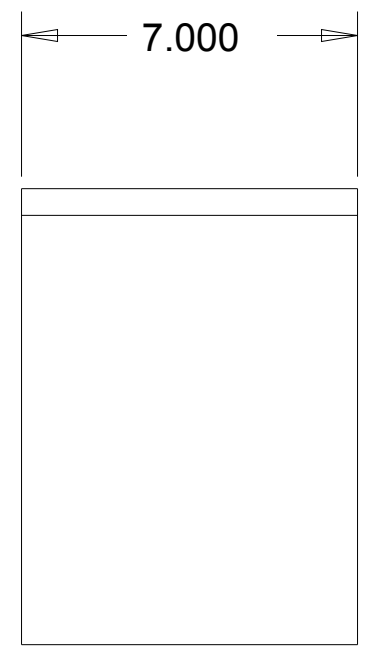
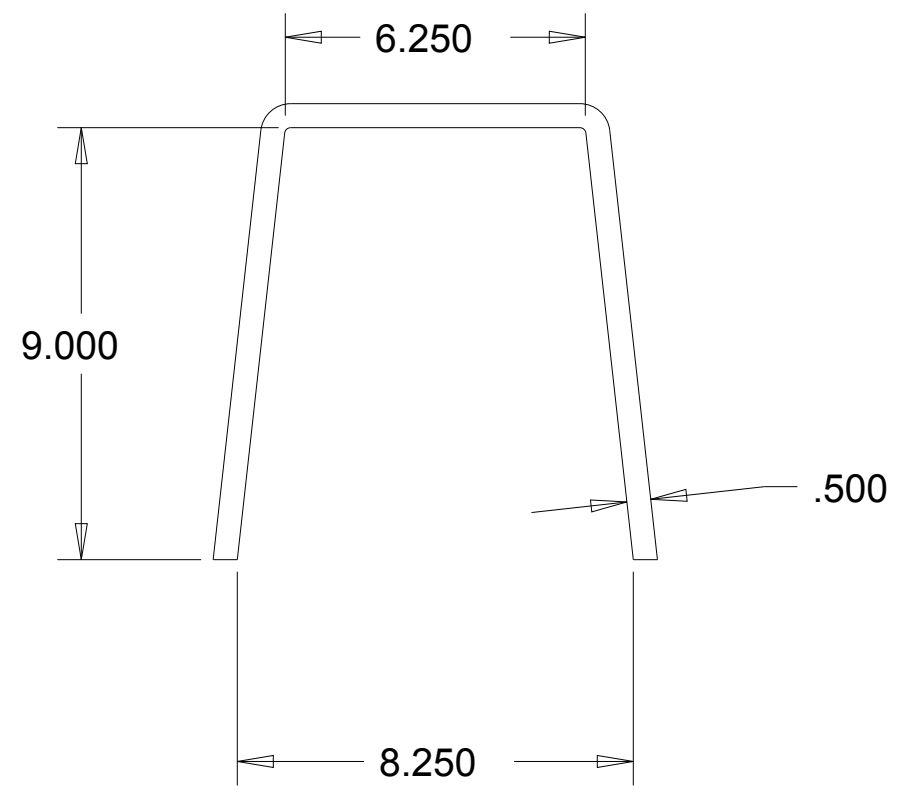

B

B

A

	SEE SHEET 1 FOR DETAILS	
	SHEET 2	

8 7 6 5 4 3

8 7 6 5 4 3 2 1

D

D

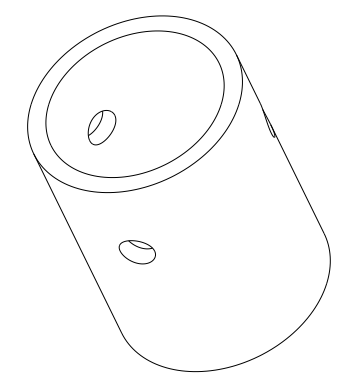
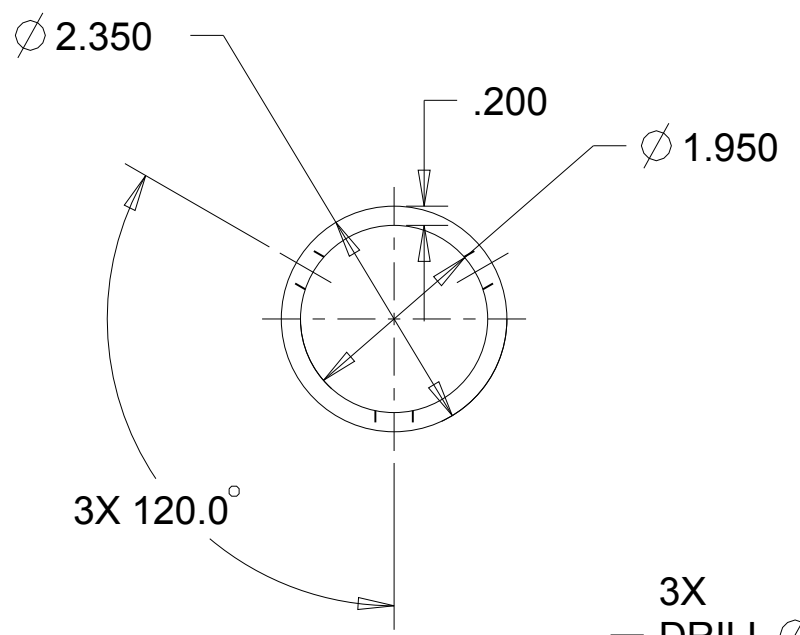

C

C

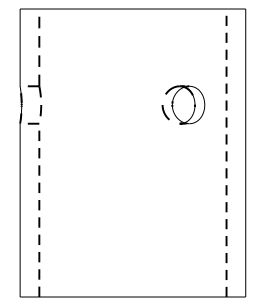
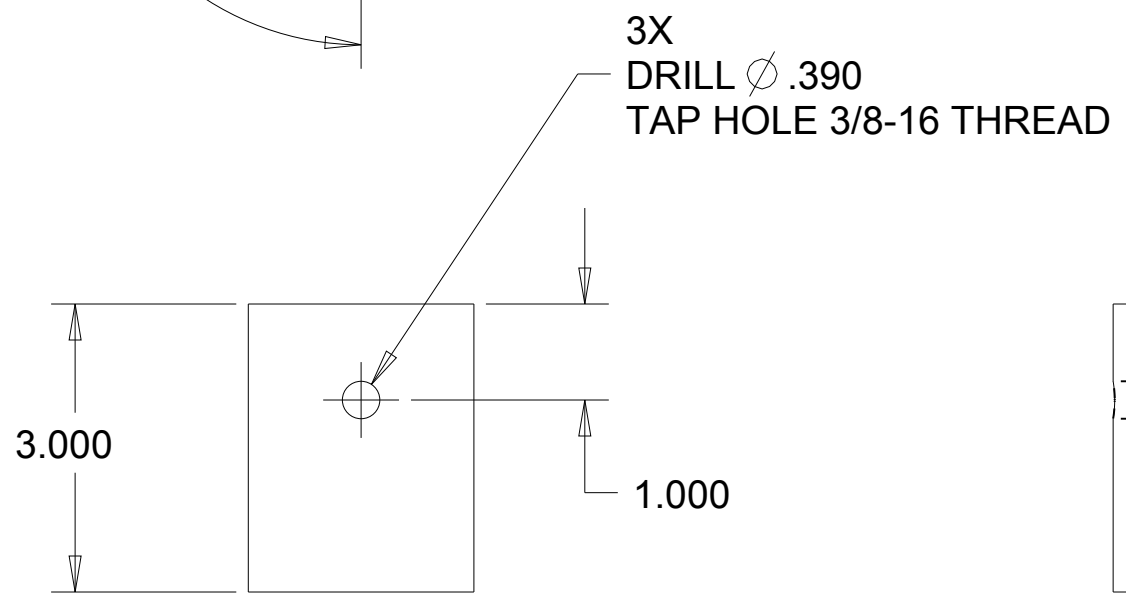

B

B

A

	SEE SHEET 1 FOR DETAILS
	SHEET 3

8 7 6 5 4 3

8 7 6 5 4 3 2 1

D

D

C

C

B

B

A

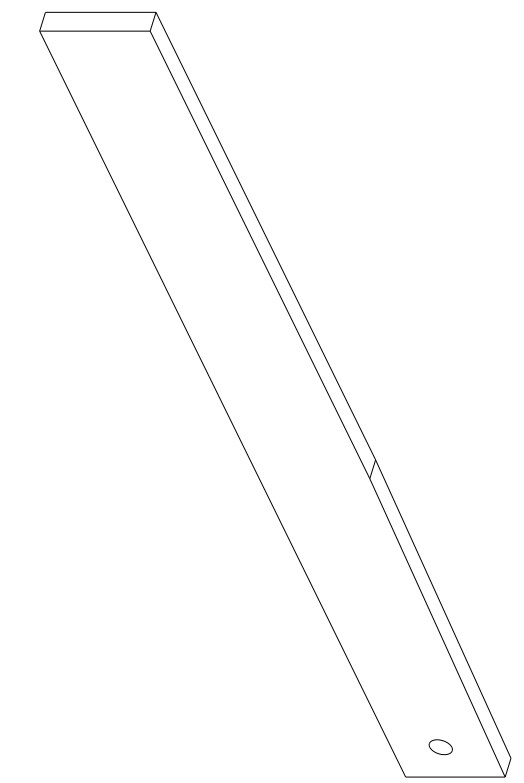
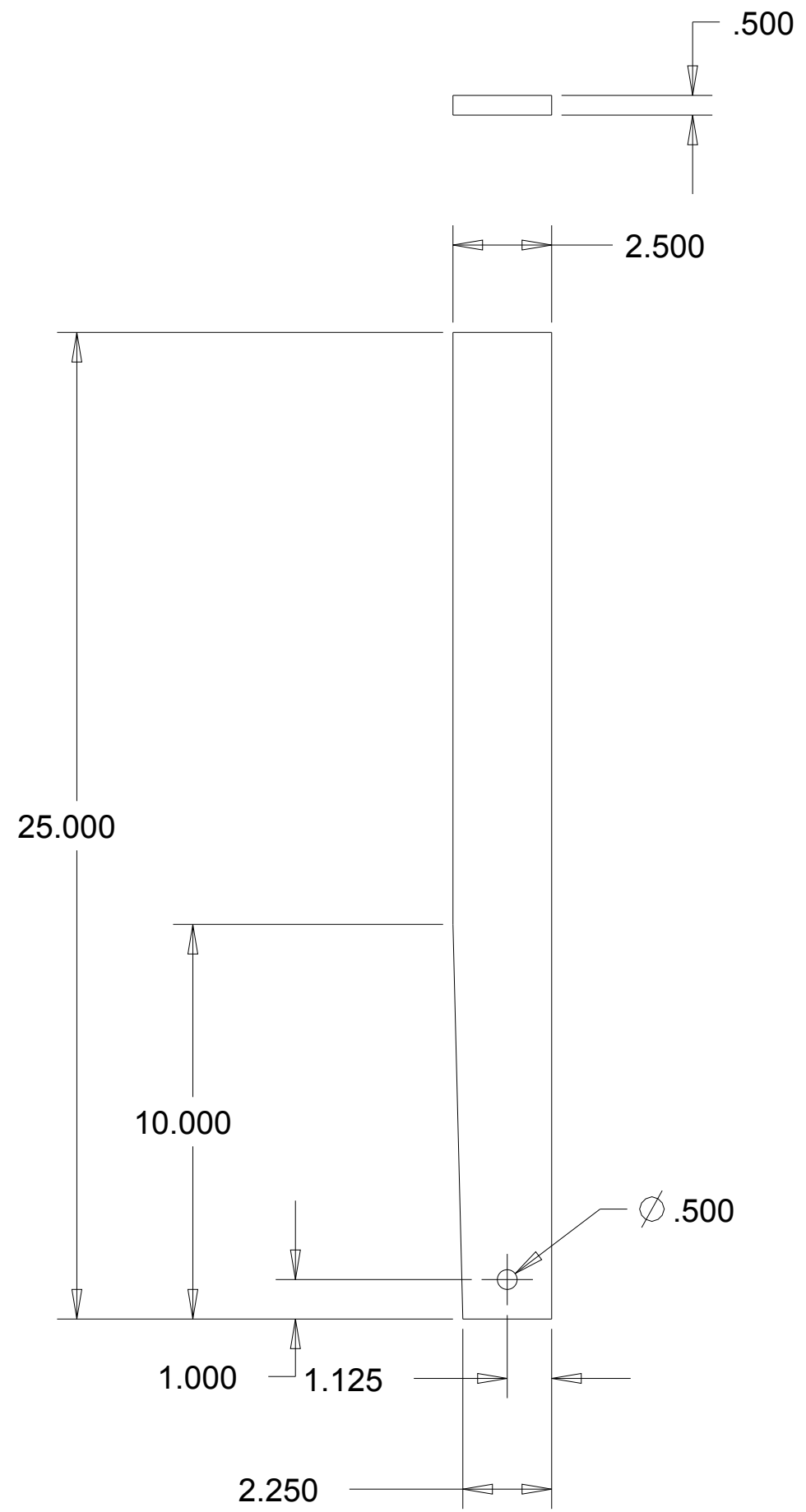

	SEE SHEET 1 FOR DETAILS	
	SHEET 4	

8 7 6 5 4 3 2 1

8

7

6

5

4

3

2

1

D

D

C

C

B

B

A

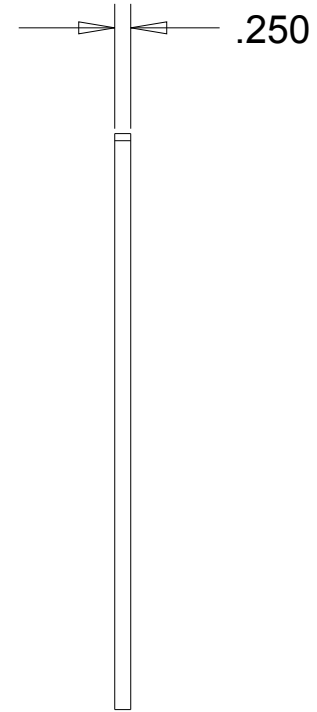
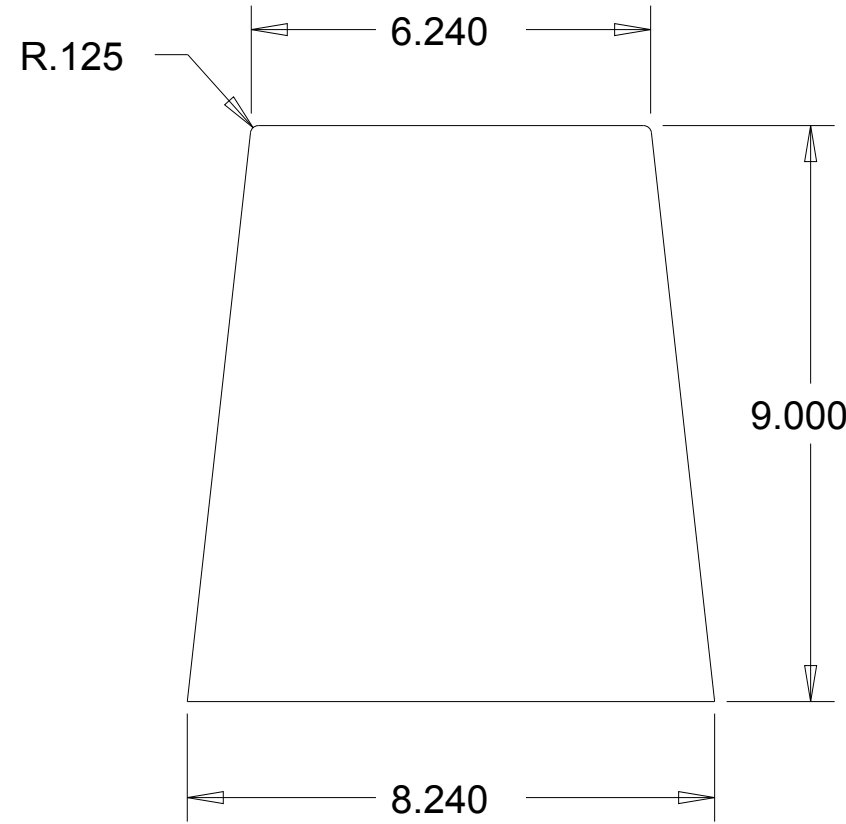

SEE SHEET 1 FOR DETAILS

SHEET 5

8

7

6

5

4

3